

INSTALLATION INSTRUCTIONS

⚠ WARNING: NEVER EXCEED YOUR VEHICLE MANUFACTURER'S RECOMMENDED TOWING CAPACITY

CLASS 3 MULTI-FIT TRAILER HITCH

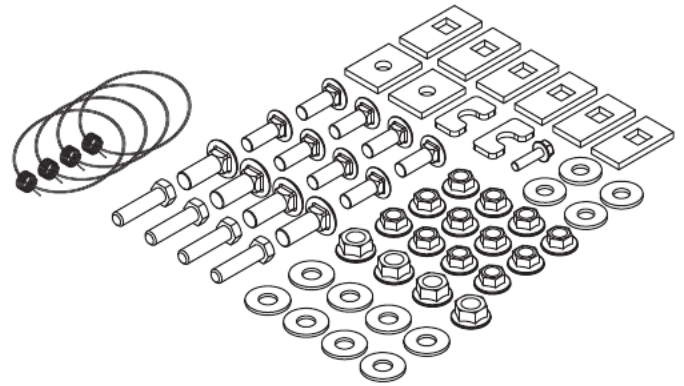
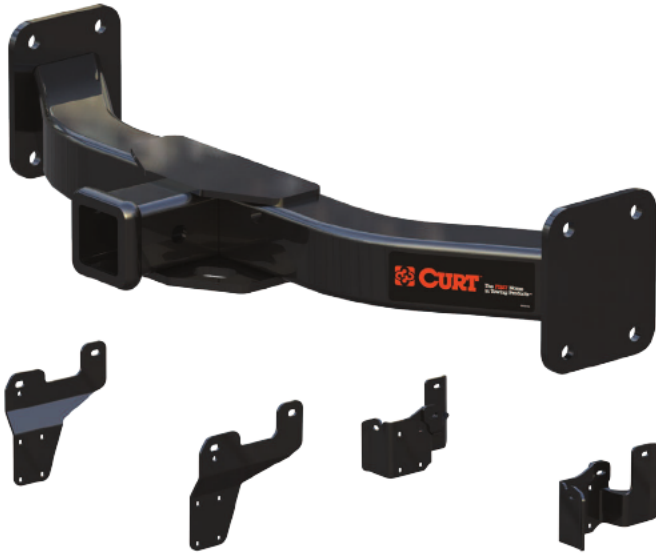

Two sets of side plates are included in this box. Only one set will be used for installation based on the vehicle application.

PARTS LIST

Parts used will vary based on application. See each page of this instruction sheet for the application-specific parts list.

Item#	Qty	Description
1	8	Carriage bolt, 1/2" - 13 x 1 1/2"
2	4	Carriage bolt, 5/8" - 11 x 1 3/4"
3	1	Flange bolt, M8 - 1.25 x 30mm
4	4	Hex head cap screw, 1/2" - 13 x 2"
5	12	Hex flange nut, 1/2" - 13
6	4	Hex flange nut, 5/8" - 11
7	4	Flat washer, 1/2"
8	8	Flat washer, 9/16"
9	4	Fishwire, 5/8" x 18"
10	6	Square hole spacer, 6mm x 1 1/4" x 2.5"
11	2	Round hole spacer, 6mm x 1 1/2" x 2"
12	2	U-shaped spacer, 5mm x 1" x 2"

WARRANTY

CURT Manufacturing, LLC, warrants this product to be free of defects in material and / or workmanship at the time of retail purchase by the original purchaser. If the product is found to be defective, CURT Manufacturing, LLC, may repair or replace the product, at their option, when the product is returned, prepaid, with proof of purchase. Alteration to, misuse of or improper installation of this product voids the warranty. CURT Manufacturing, LLC's liability is limited to repair or replacement of products found to be defective, and specifically excludes liability for incidental or consequential loss or damage.

WEIGHT RATINGS

Capacity when used as a weight carrying hitch:

8,000 lbs. gross trailer weight

800 lbs. tongue weight

Capacity when used with a weight distribution hitch:

12,000 lbs. gross trailer weight

1,200 lbs. tongue weight

FORD F-150 2006 - 2008

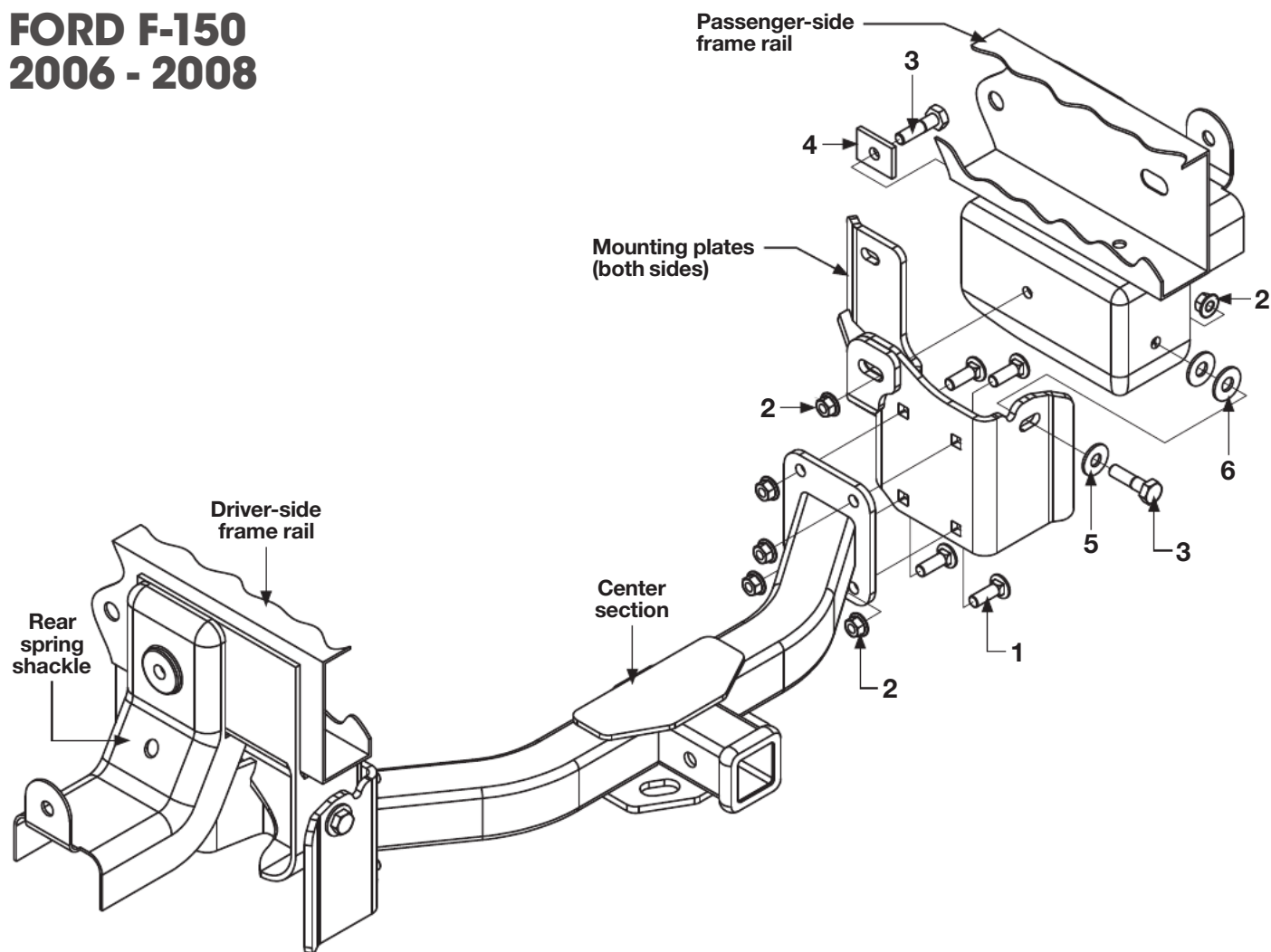

PARTS LIST

Item#	Qty	Description
1	8	Carriage bolt, 1/2" - 13 x 1 1/2"
2	12	Hex flange nut, 1/2" - 13
3	4	Hex head cap screw, 1/2" - 13 x 2"
4	2	Round hole spacer, 6mm x 1 1/2" x 2"
5	4	Flat washer, 1/2"
6	8	Flat washer, 9/16"

INSTALLATION

Step 1

Loosely attach the mounting plates to the center section with (8) 1/2" x 1 1/2" carriage bolts and (8) 1/2" hex flange nuts.

Step 2

Raise hitch into position between frame rails.

Step 3

Install remaining 1/2" fasteners as shown into each bumper bracket. Use the supplied 9/16" washers as needed between the mounting plates and frame of the vehicle.

Step 4

Torque all fasteners: 1/2" fasteners to 110 lb-ft

TOOLS NEEDED

3/4" socket
3/4" wrench

Ratchet
Torque wrench

NOTES

Hitch weight: 59 lbs.

Novice install time: 40 minutes

No drilling required

FORD F-150 2009 - 2014

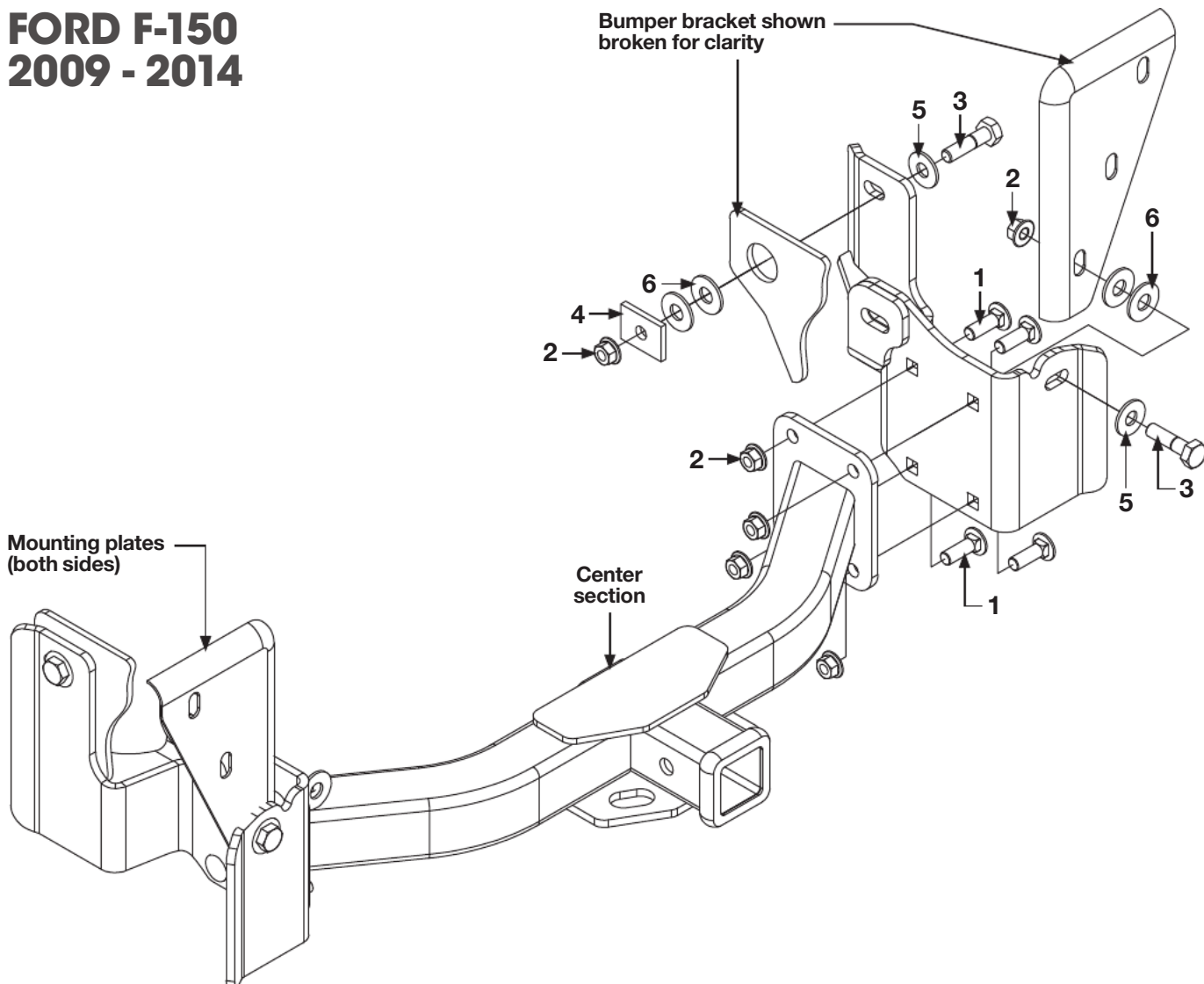

PARTS LIST

Item#	Qty	Description
1	8	Carriage bolt, 1/2" - 13 x 1 1/2"
2	12	Hex flange nut, 1/2" - 13
3	4	Hex head cap screw, 1/2" - 13 x 2"
4	2	Round hole spacer, 6mm x 1 1/2" x 2"
5	4	Flat washer, 1/2"
6	8	Flat washer, 9/16"

TOOLS NEEDED

3/4" socket
3/4" wrench
Ratchet
Torque wrench

NOTES

Hitch weight: 59 lbs.
Novice install time: 40 minutes
No drilling required
Lower spare tire (optional)

INSTALLATION

Note: Removal of the spare tire may ease hitch installation, although it is not necessary.

Step 1

Loosely attach the mounting plates to the center section with (8) 1/2" x 1 1/2" carriage bolts and (8) 1/2" hex flange nuts.

Step 2

Raise hitch into position and fasten the hitch to the bumper brackets using the supplied 1/2" fasteners as shown above. Use the supplied 9/16" washers as needed between the mounting plates and frame of the vehicle.

Step 3

Attach remaining listed fasteners as shown, placing (2) 9/16" washers inside the access hole in the bumper bracket on each side. Use the hitch and round hole spacer to retain the washers.

Step 4

Torque all fasteners: 1/2" fasteners to 110 lb-ft

Step 5

Reinstall spare tire if it was removed for hitch installation. Make sure the spare tire does not contact the bolts.

FORD F-150 2015 - PRESENT

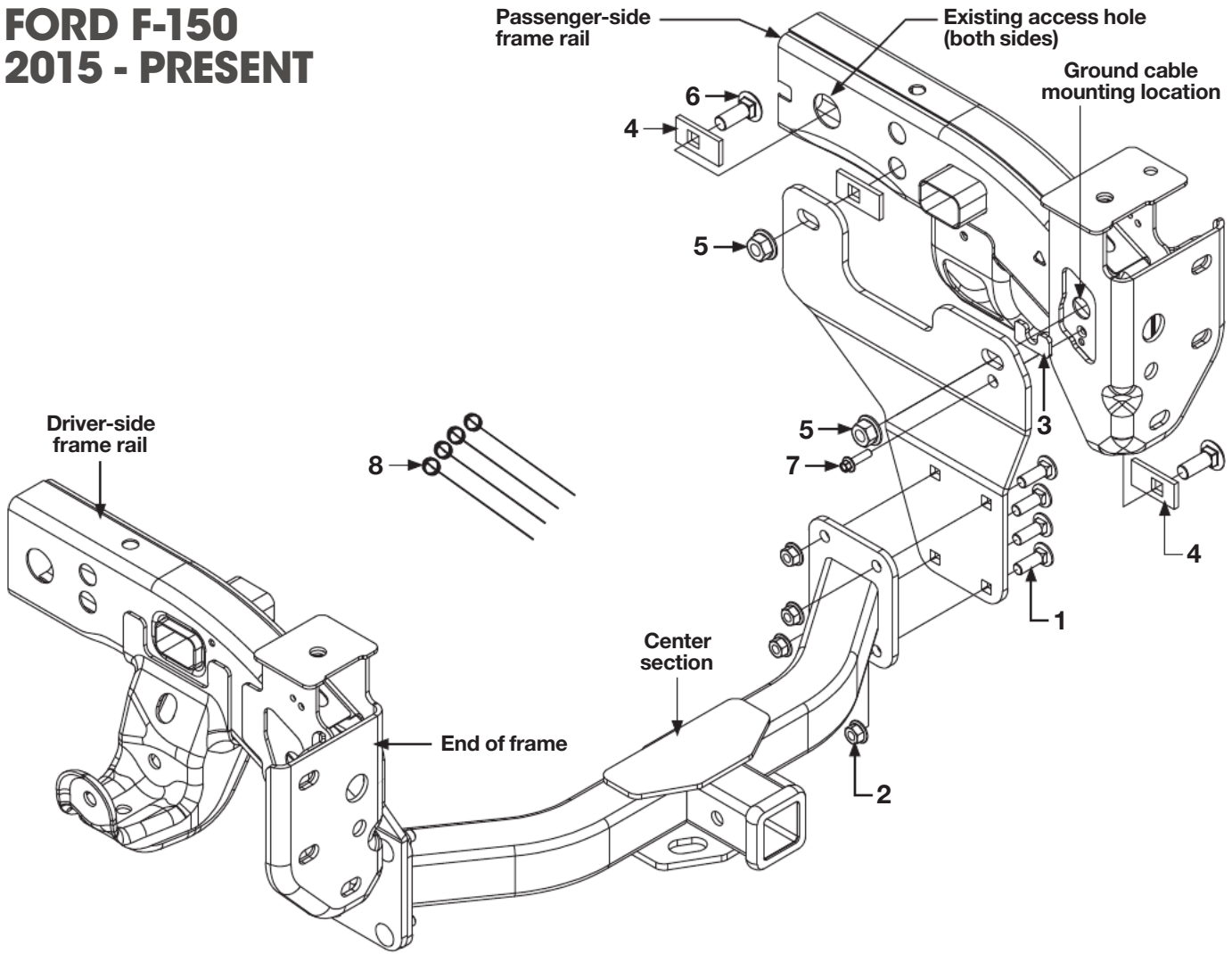

PARTS LIST

Item#	Qty	Description
1	8	Carriage bolt, 1/2" - 13 x 1 1/2"
2	12	Hex flange nut, 1/2" - 13
3	2	U-shaped spacer, 5mm x 1" x 2"
4	6	Square hole spacer, 6mm x 1 1/4" x 2.5"
5	4	Hex flange nut, 5/8" - 11
6	4	Carriage bolt, 5/8" - 11 x 1 3/4"
7	1	Flange bolt, M8 - 1.25 x 30mm
8	4	Fishwire, 5/8" x 18"

NOTES

Hitch weight: 55 lbs.

Novice install time:
60 minutes

No drilling required

Fishwire required

Temporarily remove
ground cable if present

Lower spare tire

TOOLS NEEDED

5/16" socket
3/4" socket
10mm socket
13mm socket

Ratchet
Torque wrench
Masking tape

FORD F-150 2015 - PRESENT

INSTALLATION

Step 1

Loosely attach the mounting plates to the center section with (8) 1/2" x 1 1/2" carriage bolts and (8) 1/2" hex flange nuts.

Step 2

If present, remove the grounding cable from the rear of the passenger-side frame rail. Return fastener to vehicle owner. Lower spare tire for installation.

Step 3

For the rearward most holes, tape a U-shaped spacer into the recess in the frame. Thread the forward most fishwires through another rectangular spacer on each side and then thread all of the fishwires through their appropriate mounting holes as shown on page 4.

Step 4

Fishwire (2) 5/8" carriage bolts and spacers through either an access hole or the end of the frame. Leave them in the frame and the fishwires attached. Repeat for other side.

Step 5

Raise hitch into position and pull the fishwires so the bolts are in their final position. Remove the fishwires carefully and loosely install the supplied 5/8" hex flange nuts. Reinstall the grounding cable with the supplied 8mm fastener if removed in step 1.

Step 6

Torque all fasteners:

1/2" fasteners to 110 lb-ft

5/8" fasteners to 210 lb-ft

Raise spare tire back into position.

FISHWIRE TECHNIQUE

Insert coiled end of fishwire tool through hitch mounting hole in vehicle frame rail and out the access hole. Pass coiled end of fishwire through spacer and thread bolt into coil. Kink wire to keep spacer separate from bolt as shown. Pull fishwire, spacer and bolt through frame and out mounting hole. Use fishwire to guide hitch during mounting and prevent loss of bolt or spacer inside frame rail.

